

Dornziehen

$$\varnothing Ri = 5 \times \varnothing Ro$$

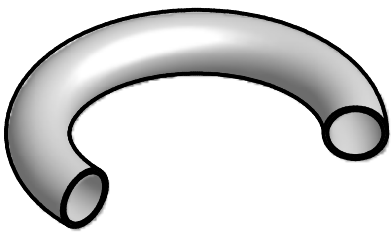
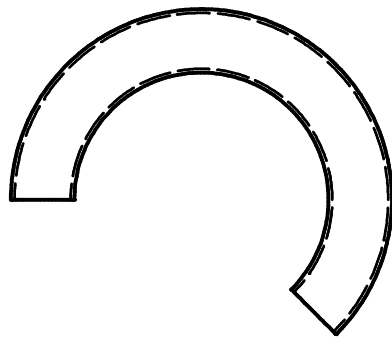
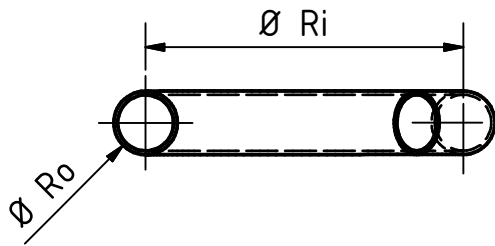

Rohr walzen

$$\varnothing Ri \geq 400 \text{ mm}$$

Kleinere Durchmesser auf Anfrage

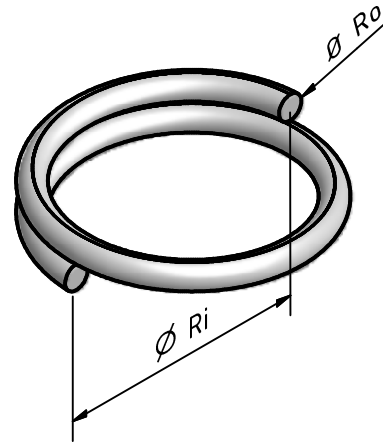
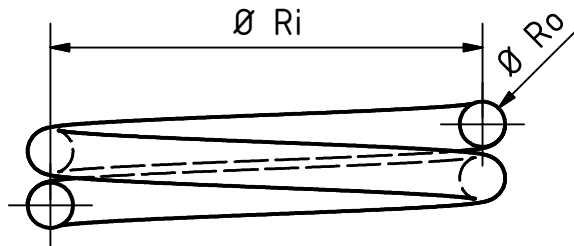

$\varnothing Ri$ = Ringdurchmesser
 $\varnothing Ro$ = Rohrdurchmesser

Rohre (Stahl-, Edelstahl-, Aluminium- & NE Metall-Rohre) mit Wandstärke > 2,5mm und gegläht!

Rohrdurchmesser	
Walzen	Dornziehen
26,9	-
33,7	33,7
42,4	42,4
48,3	48,3
60,3	50
-	60,3

www.W. Unbescheiden.de
Metal- & Apparatebau GmbH

				Datum	Name
			Gezeichnet	15.04.2008	mruen
			Kontrolliert		
			Norm		

Walzen und biegen 1
A4